

29929

Rev. 3/28/2008

**WOODS  
59CL-4 & 59CLF-4  
UNDERMOUNT  
MOWER**

**WOODS**<sup>®</sup>  
Tested. Proven. Unbeatable.

---

OPERATOR'S MANUAL

## TO THE DEALER:

Assembly and proper installation of this product is the responsibility of the Woods® dealer. Read manual instructions and safety rules. Make sure all items on the Dealer's Pre-Delivery and Delivery Check Lists in the Operator's Manual are completed before releasing equipment to the owner.

**The dealer must complete the Product Registration online at the Woods Dealer Website** or complete the mail-in form included with the Operator's Manual. If using the mail-in form, the dealer is to return the prepaid postage portion to Woods, give one copy to the customer, and retain one copy. **Failure to register the product does not diminish customer's warranty rights.**

## TO THE OWNER:

Read this manual before operating your Woods equipment. The information presented will prepare you to do a better and safer job. Keep this manual handy for ready reference. Require all operators to read this manual carefully and become acquainted with all adjustment and operating procedures before attempting to operate. Replacement manuals can be obtained from your dealer. To locate your nearest dealer, check the Dealer Locator at [www.WoodsEquipment.com](http://www.WoodsEquipment.com), or in the United States and Canada call 1-800-319-6637.

The equipment you have purchased has been carefully engineered and manufactured to provide dependable and satisfactory use. Like all mechanical products, it will require cleaning and upkeep. Lubricate the unit as specified. Observe all safety information in this manual and safety decals on the equipment.

For service, your authorized Woods dealer has trained mechanics, genuine Woods service parts, and the necessary tools and equipment to handle all your needs.

Use only genuine Woods service parts. Substitute parts will void the warranty and may not meet standards required for safe and satisfactory operation. Record the model number and serial number of your equipment in the spaces provided:

**Model:** \_\_\_\_\_ **Date of Purchase:** \_\_\_\_\_

**Serial Number: (see Safety Decal section for location)** \_\_\_\_\_

Provide this information to your dealer to obtain correct repair parts.

Throughout this manual, the term **NOTICE** is used to indicate that failure to observe can cause damage to equipment. The terms **CAUTION**, **WARNING**, and **DANGER** are used in conjunction with the Safety-Alert Symbol (a triangle with an exclamation mark) to indicate the degree of hazard for items of personal safety.



This is the safety alert symbol. It is used to alert you to potential personal injury hazards. Obey all safety messages that follow this symbol to avoid possible injury or death.



Indicates a hazardous situation which, if not avoided, will result in death or serious injury.



Indicates a hazardous situation which, if not avoided, could result in death or serious injury.



Indicates a hazardous situation which, if not avoided, could result in minor or moderate injury.

**IMPORTANT**  
or **NOTICE**

Is used to address practices not related to personal injury.

**NOTE**

Indicates helpful information.

**WOODS®**

**ALITEC™**  
**BMP®**  
**CENTRAL FABRICATORS®**  
**GANNON®**  
**GILL®**  
**WAIN-ROY®**  
**WOODS®**

## 2 Introduction

Gen'l (Rev. 2/19/2008)

# TABLE OF CONTENTS

INTRODUCTION . . . . .	2
GENERAL INFORMATION . . . . .	3
SAFETY RULES . . . . .	4
SAFETY DECALS . . . . .	6
OPERATION & SERVICE . . . . .	8
ASSEMBLY INSTRUCTIONS . . . . .	10
DEALER CHECK LISTS . . . . .	15
PARTS LISTS . . . . .	16
BOLT TORQUE CHART . . . . .	22
BOLT SIZE CHART & ABBREVIATIONS . . . . .	23
PRODUCT WARRANTY . . . . .	24
REPLACEMENT PARTS WARRANTY . . . . .	INSIDE BACK COVER

## GENERAL INFORMATION

The purpose of this manual is to assist you in operating and maintaining your mower. Read it carefully. It furnishes information and instructions that will help you achieve years of dependable performance. These instructions have been compiled from extensive field experience and engineering data. Some information may be general in nature due to unknown and varying operating conditions. However, through experience and these instructions, you should be able to develop procedures suitable to your particular situation.

The illustrations and data used in this manual were current at the time of printing but, due to possible inline

production changes, your machine may vary slightly in detail. We reserve the right to redesign and change the machines as may be necessary without notification.



■ Some illustrations in this manual show the mower with safety shields removed to provide a better view. The mower should never be operated without necessary safety shielding.



**¡LEA EL INSTRUCTIVO!**  
Si no lee Ingles, pida ayuda a alguien que si lo lea para que le traduzca las medidas de seguridad.



This Operator's Manual should be regarded as part of the machine. Suppliers of both new and second-hand machines must make sure that this manual is provided with the machine.

# SAFETY RULES



**ATTENTION! BECOME ALERT! YOUR SAFETY IS INVOLVED!**



Safety is a primary concern in the design and manufacture of our products. Unfortunately, our efforts to provide safe equipment can be wiped out by an operator's single careless act.

In addition to the design and configuration of equipment, hazard control and accident prevention are dependent upon the awareness, concern, judgement, and proper training of personnel involved in the operation, transport, maintenance, and storage of equipment.

It has been said, "The best safety device is an informed, careful operator." We ask you to be that kind of operator.

## TRAINING

- Safety instructions are important! Read all attachment and power unit manuals; follow all safety rules and safety decal information. (Replacement manuals and safety decals are available from your dealer. To locate your nearest dealer, check the Dealer Locator at [www.WoodsEquipment.com](http://www.WoodsEquipment.com), or in the United States and Canada call 1-800-319-6637.) Failure to follow instructions or safety rules can result in serious injury or death.
- If you do not understand any part of this manual and need assistance, see your dealer.
- Know your controls and how to stop engine and attachment quickly in an emergency.
- Operators must be instructed in and be capable of the safe operation of the equipment, its attachments, and all controls. Do not allow anyone to operate this equipment without proper instructions.
- Never allow children or untrained persons to operate equipment.

## PREPARATION

- Check that all hardware is properly installed. Always tighten to torque chart specifications unless instructed otherwise in this manual.
- Always wear relatively tight and belted clothing to avoid getting caught in moving parts. Wear sturdy, rough-soled work shoes and protective equipment for eyes, hair, hands, hearing, and head; and respirator or filter mask where appropriate.
- Make sure attachment is properly secured, adjusted, and in good operating condition.
- Remove accumulated debris from this equipment, power unit, and engine to avoid fire hazard.

- Make sure all safety decals are installed. Replace if damaged. (See Safety Decals section for location.)
- Make sure shields and guards are properly installed and in good condition. Replace if damaged.
- Inspect and clear area of stones, branches, or other hard objects that might be thrown, causing injury or damage.

## OPERATION

- You may not be able to stop the tractor safely if the clutch or brake pedal mechanisms are improperly adjusted, allowing them to contact mower components.
- When the mower lift stops are installed as instructed in this manual, properly adjusted clutch and brake pedal mechanisms will not contact mower components. You should frequently check that the tractor clutch and brake pedal mechanisms are in adjustment.
- If the clutch or brake pedal mechanisms can contact mower components, do not put mower into service until properly adjusted.
- Do not put mower into service unless discharge chute is installed and in good condition. Replace if damaged.
- Keep bystanders away from equipment.
- Do not operate or transport equipment while under the influence of alcohol or drugs.
- Never direct discharge toward people, animals, or property.
- Operate only in daylight or good artificial light.
- Keep hands, feet, hair, and clothing away from equipment while engine is running. Stay clear of all moving parts.
- Always comply with all state and local lighting and marking requirements.
- Never allow riders on power unit or attachment.
- Always sit in power unit seat when operating controls or starting engine. Place transmission in neutral, engage brake, and ensure all other controls are disengaged before starting power unit engine.
- Look down and to the rear and make sure area is clear before operating in reverse.
- Do not operate or transport on steep slopes.
- Do not stop, start, or change directions suddenly on slopes.



# SAFETY RULES

**ATTENTION! BECOME ALERT! YOUR SAFETY IS INVOLVED!**



- Use extreme care and reduce ground speed on slopes and rough terrain.
- Watch for hidden hazards on the terrain during operation.
- Stop power unit and equipment immediately upon striking an obstruction. Turn off engine, remove key, inspect, and repair any damage before resuming operation.

## TRANSPORTATION

- Always comply with all state and local lighting and marking requirements.
- Never allow riders on power unit or attachment.
- Do not operate PTO during transport.
- Watch for hidden hazards on the terrain.
- Do not operate or transport on steep slopes.
- Do not operate auxiliary hydraulics during transport.
- Do not operate or transport equipment while under the influence of alcohol or drugs.

## MAINTENANCE

- Before dismounting power unit or performing any service or maintenance, follow these steps: disengage power to equipment, lower the 3-point hitch and all raised components to the ground, operate valve levers to release any hydraulic pressure, set parking brake, stop engine, remove key, and unfasten seat belt.
- Do not modify or alter or permit anyone else to modify or alter the equipment or any of its components in any way.
- Always wear relatively tight and belted clothing to avoid getting caught in moving parts. Wear sturdy, rough-soled work shoes and protective equipment for eyes, hair, hands, hearing, and head; and respirator or filter mask where appropriate.
- Never go underneath equipment (lowered to the ground or raised) unless it is properly blocked and secured. Never place any part of the body underneath equipment or between moveable parts even when the engine has been turned off. Hydraulic

system leak down, hydraulic system failures, mechanical failures, or movement of control levers can cause equipment to drop or rotate unexpectedly and cause severe injury or death. Follow Operator's Manual instructions for working underneath and blocking requirements or have work done by a qualified dealer.

- Make sure attachment is properly secured, adjusted, and in good operating condition.
- Keep all persons away from operator control area while performing adjustments, service, or maintenance.
- Make certain all movement of equipment components has stopped before approaching for service.
- Frequently check blades. They should be sharp, free of nicks and cracks, and securely fastened.
- Do not handle blades with bare hands. Careless or improper handling may result in serious injury.
- Your dealer can supply genuine replacement blades. Substitute blades may not meet original equipment specifications and may be dangerous.
- Tighten all bolts, nuts, and screws to torque chart specifications. Check that all cotter pins are installed securely to ensure equipment is in a safe condition before putting unit into service.
- Make sure all safety decals are installed. Replace if damaged. (See Safety Decals section for location.)
- Make sure shields and guards are properly installed and in good condition. Replace if damaged.
- Wear gloves when installing belt. Be careful to prevent fingers from being caught between belt and pulley.

## STORAGE

- Block equipment securely for storage.
- Keep children and bystanders away from storage area.







# SAFETY & INSTRUCTIONAL DECALS

**ATTENTION! BECOME ALERT! YOUR SAFETY IS INVOLVED!**

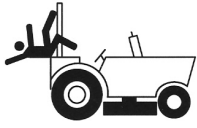

**Replace Immediately If Damaged!**

## 1 - PN 19007

 <b>WARNING</b>	
	
<p><b>FALLING OFF CAN RESULT IN BEING RUN OVER.</b></p> <ul style="list-style-type: none"> <li>Tractor must be equipped with ROPS (or ROPS CAB) and seat belt. Keep foldable ROPS systems in "locked up" position at all times.</li> <li>Buckle Up! Keep seat belt securely fastened.</li> <li>Allow no riders.</li> </ul> <p><b>RAISED EQUIPMENT CAN DROP AND CRUSH.</b></p> <ul style="list-style-type: none"> <li>Before working underneath, follow all instructions and safety rules in operator's manual and securely block up all corners of equipment with jack stands.</li> <li>Securely blocking prevents equipment dropping from hydraulic leak-down, hydraulic system failures or mechanical component failures.</li> </ul> <p><b>FALLING OFF OR FAILING TO BLOCK SECURELY CAN RESULT IN SERIOUS INJURY OR DEATH.</b></p> <p style="text-align: right;">19007-A</p>	

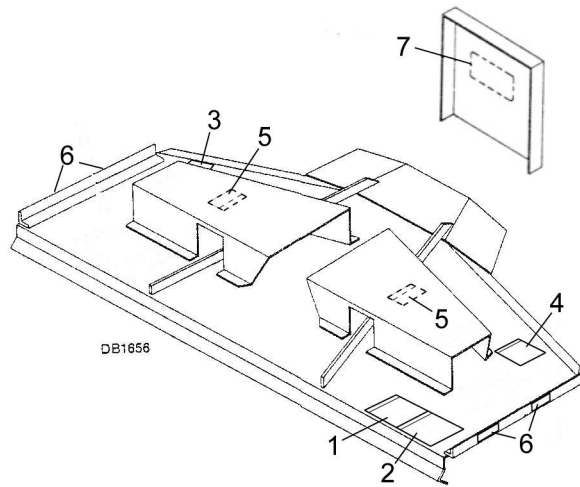

## 3 - SERIAL NUMBER PLATE

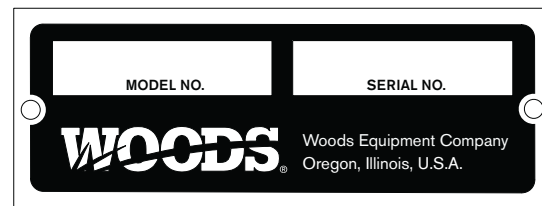

## 2 - PN 53425

 <b>DANGER</b>		
		
<p style="text-align: center;"><b>ROTATING BLADES AND THROWN OBJECTS</b></p> <ul style="list-style-type: none"> <li>Do not put hands or feet under or into mower when engine is running.</li> <li>Before mowing, clear area of objects that may be thrown by blade.</li> <li>Keep bystanders away.</li> <li>Keep discharge chute and guards in place and in good condition.</li> </ul> <p style="text-align: center;"><b>BLADE CONTACT OR THROWN OBJECTS CAN CAUSE SERIOUS INJURY OR DEATH.</b></p> <p style="text-align: right;">53425-B</p>		

### BE CAREFUL!

Use a clean, damp cloth to clean safety decals.

Avoid spraying too close to decals when using a pressure washer; high-pressure water can enter through very small scratches or under edges of decals causing them to peel or come off.

Replacement safety decals can be ordered free from your Woods dealer. To locate your nearest dealer, check the Dealer Locator at [www.WoodsEquipment.com](http://www.WoodsEquipment.com), or in the United States and Canada call 1-800-319-6637.



# SAFETY & INSTRUCTIONAL DECALS

**ATTENTION! BECOME ALERT! YOUR SAFETY IS INVOLVED!**  
**Replace Immediately If Damaged!**



4 - PN 18877

<b>WARNING</b>
<p><b>TO AVOID SERIOUS INJURY OR DEATH:</b></p> <ul style="list-style-type: none"> <li>■ Read Operator's Manual (available from dealer) and follow all safety precautions.</li> <li>■ Keep all shields in place and in good condition.</li> <li>■ Operate mower from tractor seat only.</li> <li>■ Lower mower, stop engine and remove key before dismounting tractor.</li> <li>■ Allow no children or untrained persons to operate equipment.</li> <li>■ Do not transport towed or semi-mounted units over 20 mph.</li> </ul> <p style="text-align: center;"><b>FAILURE TO OPERATE SAFELY CAN RESULT IN INJURY OR DEATH.</b></p> <p style="text-align: right; font-size: small;">18877-C</p>

5 - PN 18868

<b>DANGER</b>
<p><b>SHIELD MISSING</b>          Do not operate.          Put shield on.</p> <p style="text-align: right; font-size: small;">18868-B</p>

6 - PN 18869

<b>DANGER</b>
<p><b>SHIELD MISSING</b>  <b>DO NOT OPERATE - PUT SHIELD ON</b></p> <p style="text-align: right; font-size: small; writing-mode: vertical-rl; transform: rotate(180deg);">18869-B</p>

7 - PN 23376

<b>CAUTION</b>
<p><b>ALWAYS USE 1000 RPM PTO SPEED.</b></p> <p style="text-align: right; font-size: small;">23376</p>

# OPERATION & SERVICE

## **MOWING GRASS**

Woods mowers are equipped with suction-type blades which make them ideal for finish mowing large areas of lawn.

The machine should be run level when mowing, and the uncut area kept to the left side (right side on left-hand machine) to prevent small windrow that might otherwise occur.

## **Streaking**

With certain types of grass and under certain seasonal conditions, the front caster wheels may roll the grass down enough that it will not come all the way back up and will not be cut as short as the surrounding area.

This may appear to be a streak left by the spindle, but it is not. The only solution, under these conditions, is to carry the weight of the machine on the lift chains with the caster wheels adjusted up so they carry the weight when riding a high ridge or high spot.

## **TRACTOR OPERATING INSTRUCTIONS**

Operate the tractor at full governed rpm when doing normal mowing. If the forward speed is too high, a lower gear can be used.

## **Height Adjustment (Without Casters)**

The mower is raised, lowered and mowing height maintained by the tractor hydraulic system. Set the hydraulic control lever stop for the mowing level desired; then adjust the side skids so that they just clear the ground. The side skids will then minimize scalping by lifting the mower over bumps.

## **Height Adjustment (With Casters)**

The mower may be raised off the casters at any time by the tractor lift system, but regulate mowing height with caster height. Adjust mowing height by transferring spacers from below the caster mounting bracket to above it or vice versa and by moving wheel up or down in holes in wheel yoke.

## **Attitude Adjustment**

The rotary mower can be adjusted to ride level at various cutting heights by adjusting the rear of the machine up or down in the mounting bracket holes. After changing the height of the rear of the mower, always check the alignment of the belt from the idlers forward. If the belt is out of line, move the entire mower forward or back in the side adjustment holes or adjust idlers as

necessary to make the belt run true. The side adjustment holes are also for additional belt takeup in case belt adjustment is used on the idlers. It is very important to run the belt as much in line as possible at all times.

## **Lubrication**

Lubricate the blade spindle shafts with SAE 80 or 90EP gear lube every 24 hours of operation until some oil is forced out around the top of the shaft. If machine is equipped with casters, grease occasionally to keep the powdered metal bearing well lubricated. The V-belt idlers have sealed ball bearings and do not need lubricating. On mowers using chain drive and jackshaft, keep chain well oiled and grease jackshaft every 24 hours of operation.

## **V-Belts**

Belts should be adjusted so that they are tight enough to hold the power of the tractor when mowing. The mowers for IH Cub tractors are designed so that as the mower is raised above the mowing position, the belt slackens. This is to prevent excessive load on the tractor PTO pilot bearing when the tractor motor is operated with PTO disengaged. Thus, on Cubs, the operator should avoid adjusting the drive belt so tight that the slackening off effect is eliminated. On other tractors, to prevent belt from jumping off, the belt should be adjusted so it is snug and not tight when mower is raised.

When belt replacement is necessary, use only belts recommended by Woods dealers. These are of special construction for shock loading and severe use.

## **Side Shield & Discharge Chute**

Both a side shield and a discharge chute are provided for the discharge end of mower (left end on white mower frames and right end of yellow frames). The side cover shield should be used in light mowing and when mowing in areas where other persons may be present. The discharge chute is used in heavy mowing to allow easier escape of cut material. Always use either side shield or discharge chute.

## **OPTIONAL EQUIPMENT**

Two caster wheels are available for mounting on the front of the mower. This will gage the mowing height very accurately. The leaf mulcher disposes of leaves quickly and economically. It returns valuable organic material to the soil.



## **MOWER SPINDLE ASSEMBLIES**

Mower spindles are equipped with two tapered roller bearings. The proper adjustment is held by a spring pin. It is not intended that these bearings be adjusted during their useful life. When difficulty is experienced with the mower spindle assembly, time and trouble will be saved by buying a completely new spindle assembly.

However, if bearings must be adjusted, the spring pin can be driven out, the sleeve pulled loose, and a washer shim placed under the sleeve to tighten the bearings.

## **SERVICING CUTTING BLADES**

Blades are made of heat-treated alloy steel and are designed to produce the most satisfactory results. For a good mowing job, always keep blades sharp.

**NOTE:** On left hand models (L - White Frame) the blade bolts have left-hand threads.

## **MODEL 59 MOWER**

This mower does not have friction blade clutch. The bolt which is used to fasten the blade to the mower spindle shaft has a nylon insert to prevent it from blacking out too easily. Do not substitute an ordinary bolt. When replacing the blade, tighten the bolt tight enough so that the blade will not slip.

## **CLEANING**

### **After Each Use**

- Remove large debris such as clumps of dirt, grass, crop residue, etc. from machine.
- Inspect machine and replace worn or damaged parts.
- Replace any safety decals that are missing or not readable.

### **Periodically or Before Extended Storage**

- Clean large debris such as clumps of dirt, grass, crop residue, etc. from machine.
- Remove the remainder using a low-pressure water spray.
  1. Be careful when spraying near scratched or torn safety decals or near edges of decals as water spray can peel decal off surface.
  2. Be careful when spraying near chipped or scratched paint as water spray can lift paint.
  3. If a pressure washer is used, follow the advice of the pressure washer manufacturer.
- Inspect machine and replace worn or damaged parts.
- Sand down scratches and the edges of areas of missing paint and coat with Woods spray paint of matching color (purchase from your Woods dealer).
- Replace any safety decals that are missing or not readable (supplied free by your Woods dealer). See Safety Decals section for location drawing.

# ASSEMBLY

Assembly of this mower is the responsibility of the Woods dealer. It should be delivered to the owner completely assembled, lubricated, and adjusted for normal cutting conditions.

Refer to mower frame assembly illustrations and parts list. Lay out parts and hardware on a clean surface to aid in assembly.

## WARNING

- Keep all persons away from the operator control area while performing adjustments, service or maintenance.

## CAUTION

- Always wear relatively tight and belted clothing to avoid entanglement in moving parts. Wear sturdy, rough-soled work shoes and protective equipment for eyes, hands, hearing and head.

### Side Shields (See page 16)

Attach side shields to the mower with 3/8 x 1" cap screws and flange lock nuts. A side discharge chute (60) may be installed on the right end of the mower in place of side shield (54).

### Center Belt Shield (See page 16)

Bolt center belt shield bracket (21) to mower deck in hole just behind center spindle using 3/8 x 1" bolt, lock washer and nut. Bolt center shield (22) to this bracket and to deck, using the three bolts welded in them. Secure with 3/8" nuts and lock washers.

### Side Skids (See page 16)

Bolt the side skids on in such a position that they will be carried close to the ground when the mower is operated at the desired mowing height. Use 3/8 x 1-1/4 heat treated bolts (torque to 35 lbs-ft) lock washers and nuts.

### Fast Hitch

To use **59CLF-4 with Fast Hitch**, accessory kit 10570 must be used.

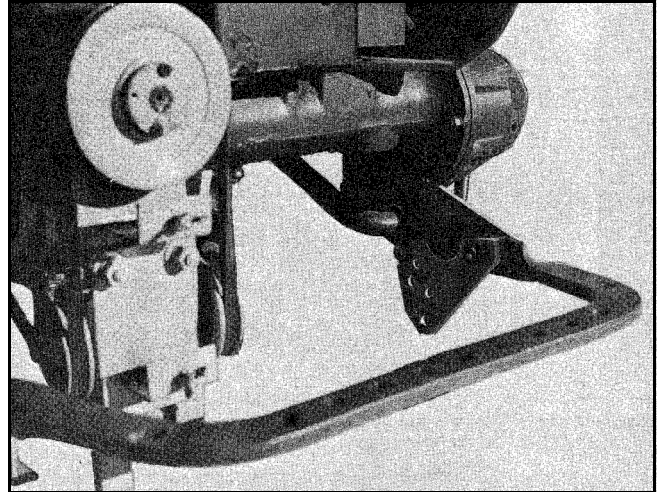

Figure 1. Photo of Mounting Plate Supplied in 10570 and Installation of Attachment Bracket

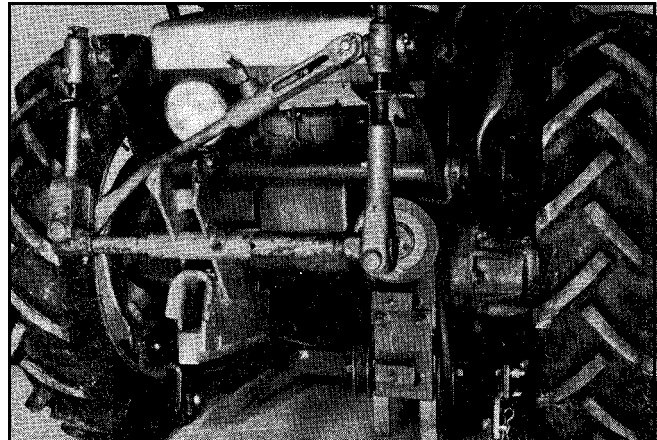

Figure 2. 59CLF-4 with Fast Hitch Shown Mounted on Cub Lo-Boy Tractor with all of the Fast Hitch Equipment Installed

Remove the drawbar mounting plates for the Fast Hitch from the Fast Hitch. Replace with special mounting plates supplied in the kit.

### Front Toe Guards (See page 16)

Front toe guards (59) are furnished for some mowers. When provided, bolt them to front of mower, using 3/8 NC x 3/4" carriage bolts and 3/8" flange lock nuts.

### Attachment Arms

For tractors with fast hitch, see page 16. Bolt attachment arms (31) and (40) to inside of drawbar mounting brackets on the tractor with one 5/8 x 1-3/4" cap screw and lock washer and one 1/2 x 2-1/2" cap screw, flat washer, lock washer, and nut in each. If drawbar is not used, place a 5/8 x 1-3/8 x 5/8" washer between verti-

cal push arms (31 and 40) and attachment brackets (32) and (39).

### Idler Bracket Assembly (See Figure 9 & page 16)

Remove the cap screws from the PTO bearing plate. Bolt the idler bracket assembly (36, 37, 38 and 45) to the tractor using 3/8 x 1-1/2" cap screws and lock washers.

### Sheave for Belt Pulley Shaft (See page 16)

Remove paint from bore of sheave (41). Put 1" splined tapered bushing in sheave (41) and insert screws to hold bushing in place, but DO NOT TIGHTEN. Slide sheave and bushing on PTO shaft and leave loose until belts are put on and lined up. After proper alignment is obtained, tighten bushing bolts evenly to 12 lbs-ft of torque, alternating back and forth at least six times.

### Mount Mower (See page 16)

Slide mower under tractor, attach crosswise rear support (35) to the two channel arms (33) using 5/8 x 1-1/2" clevis pins and safety pins (28).

### Channel Arms (See page 16)

Attach two channel arms (33) with single bore hole end to the mower, using 5/8 x 1-1/2 clevis pins and safety pins. Use upper hole in arms for high grass. Attach channel arms to brackets (31 & 40) using 5/8 x 1-3/4 clevis pins.

Attach the crosswise rear support (35) to the mower frame using one 1/2 x 2" cap screw, pivot bushing (34) and flange lock nut.

### Lifting Assembly (See page 16)

Attach the lift assembly to right hydraulic arm of the tractor, using two 5/8 x 1-3/4 cap screws, lock washer and nut.

Attach two 10-link lift chains (9) to the key holes in lift lugs on mower frame and secure with plastic caplug. Attach upper end of chains to the eye bolts of lift assembly.

Raise the mower on the tractor hydraulic system slightly and adjust the chain to carry the mower level. Adjust stops on lift control lever so mower will not hit tires or bottom of tractor when fully raised.

## Belt Assembly & Adjustment

First put belt on bottom groove, right hand side of the center sheave. Then thread it to the left, around the left hand sheave.

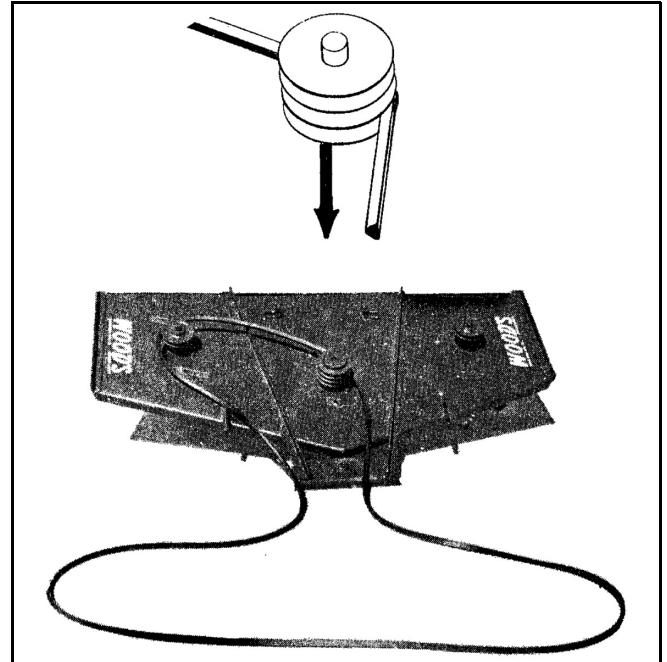

Figure 3. Belt Installation

Bring the belt back across the center sheave in the center groove over to the right outside sheave.

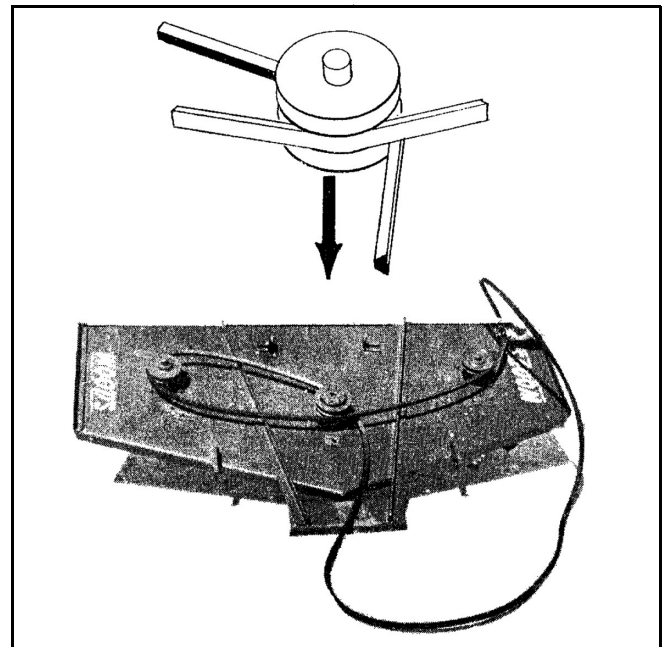
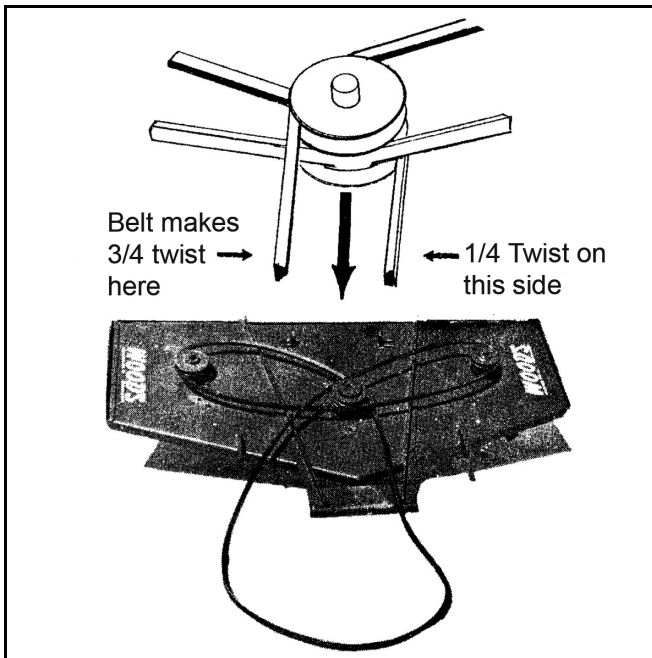

Figure 4. Belt Installation

Then thread it back across the front of the center sheave in the top groove.



**Figure 5. Belt Installation**

**Proper Twist:** The belt then follows with a 3/4 twist back under the left V-idler, up over the drive sheave and back down under the right idler pulley. This will leave a 1/4 twist in the section of belt extending from the right V-idler to lower groove of the center mower sheave. If not installed correctly, more twist will result than is allowable.

Adjust the mower to proper cutting height. The front of the mower should be slightly lower than the rear for the best cutting and least power requirement.

**Idler Adjustment:** Make minor belt adjustment with idlers but keep left idler about 1" above being in line with the groove in which the belt runs on the center sheave of the mower and right idler about 1" below. Move mower fore and aft for major adjustments.

## Belt Troubleshooting

### Belt Whip

Belt whip is caused by belt misalignment unless mower is driven by a rough-running or 2-cylinder engine. On certain models a belt guide is provided to dampen out the whip on the loose side. The guide should be set to just clear the belt in normal position.

### Proper Position of 59

Adjust mower forward and back to such a position that the rear take-up idlers are near the bottom of their slots when the belt lines up with the proper groove in the center pulley and is tight. Never run the idlers high in the slots as this will cause misalignment.

It is assumed that the mower is adjusted to run approximately level. If the front of the mower is down, the idlers will have to be raised. If the back of the mower is down, the idlers will have to be down further. Belts must be in proper alignment with sheave grooves as shown in Figure 6 through Figure 8.

### PTO Pulleys

PTO Pulleys must be moved in or out to cause the belt to be in alignment with the idlers.

### Belt Tension

Run belts very tight. Slipping will heat and ruin a belt but tension is not harmful.

### Use of Straight Edge (Side View)

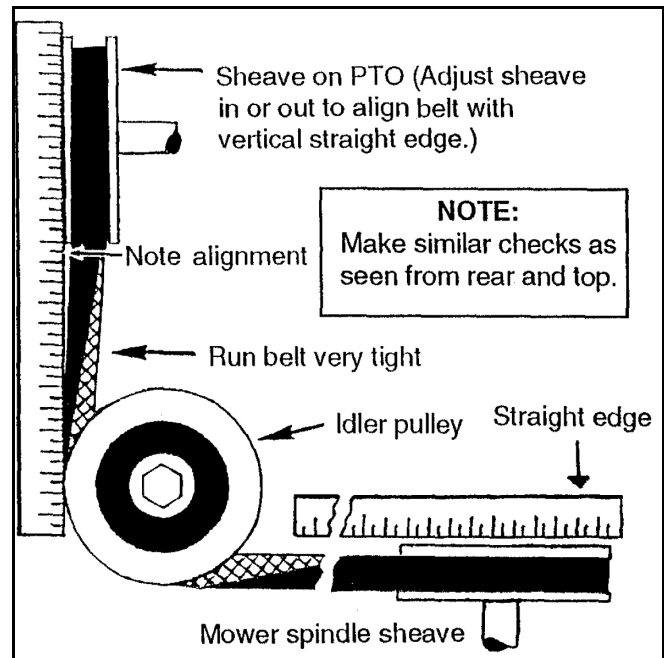

**Figure 6. Use of Straight Edge**

### How to Align a Twisted Belt

**Right:** Inside edges of the belt are approximately lined up with the sheave.

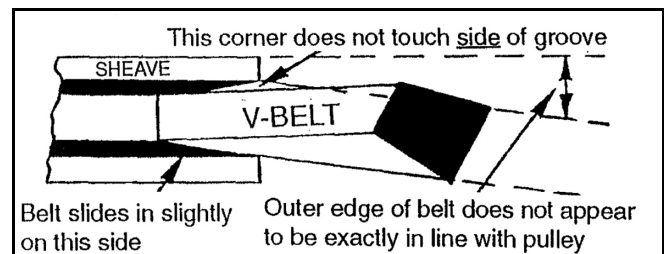

**Figure 7. Correct Alignment**

**Wrong:** Outer edge of belt appears to be in line.

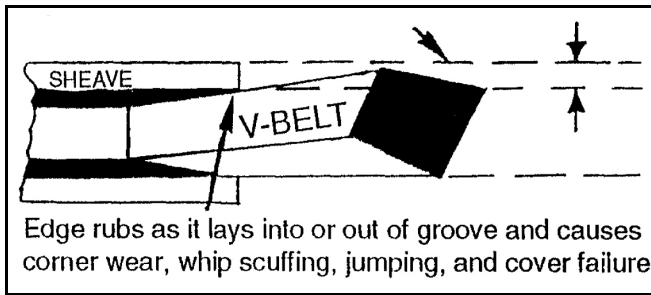

**Figure 8.** Incorrect Alignment

## V-Belt Shield (See page 16)

Place the V-belt shield (43) over the rear drive and secure with wing nut.

## Casters

The caster bundle includes one right and one left caster assembly, which, on most tractors, is assembled with the offset away from front wheels, but on 59CL mounted on IH Cub Lo-Boy, the left caster must be offset away from carburetor on the tractor. Therefore, right caster will offset outward toward front tire. The front tractor wheels should be moved out about 6" from narrowest position to provide room for caster wheel to turn when backing up.

## Leaf Mulcher

Turn mower upside down on saw horses. If mower has a bolt-on front shield, adjust shield all the way down in

long slots. Remove side shields. Leave side skids on. If optional front roller has been installed, it must be removed.

On mowers with bent-down front frame, remove center baffle and drill two 7/16 diameter holes in front of mower at the dimensions shown on page 21.

Attach slotted angles (2) to leaf mulcher as shown in drawing.

Place leaf mulcher over blades on mower. Attach angles (2) to mower side shields to side frame angle on mower. Mowers with bolt-on front shields will use front shield hole to attach angle (2). Bolt side shields to mower using 3/8 flat washers for spacers.

On mowers with bolt-on front shield, bolt front of leaf mulcher to bottom of slots in front shield with 3/8 x 1" bolts and flat washers. On mowers with bent-down front frame, bolt leaf mulcher to inside of mower in holes drilled in front frame using 3/8 x 1-1/2" bolts and 5/8 long pipe spacers between leaf mulcher and mower. On some mowers where 5/8" pipe may be too long, substitute 3/8 flat washers.

Drill 7/16 holes in rear of mower deck through holes in leaf mulcher rear plates and bolt rear of leaf mulcher to deck using 3/8 x 1" bolts.

Tighten all bolts securely. Turn each blade individually inside the leaf mulcher to see that it clears the leaf mulcher rings. If necessary, the rings may be re-shaped with a hammer to clear the leaf mulcher rings.

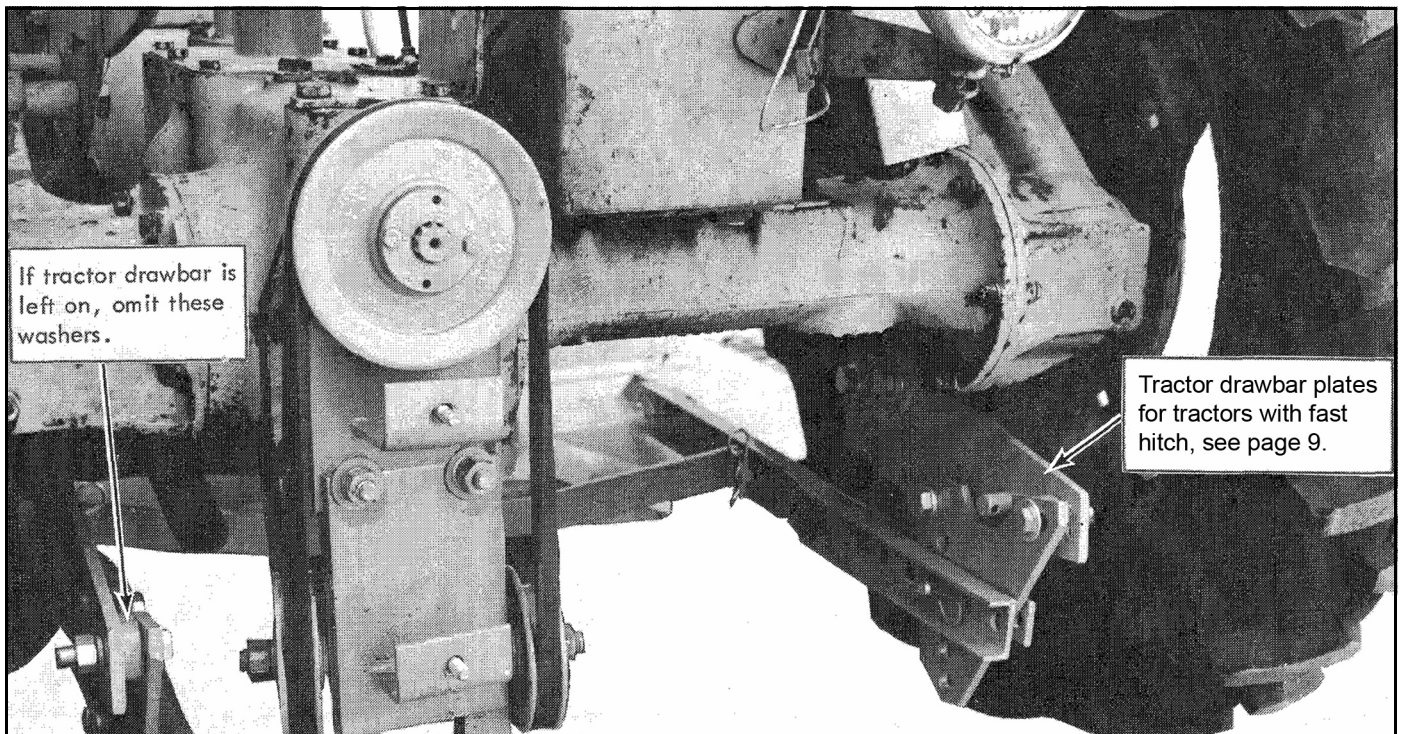

**Figure 9.** 59CL-4 Idler Bracket and Mounting Assembly Photo

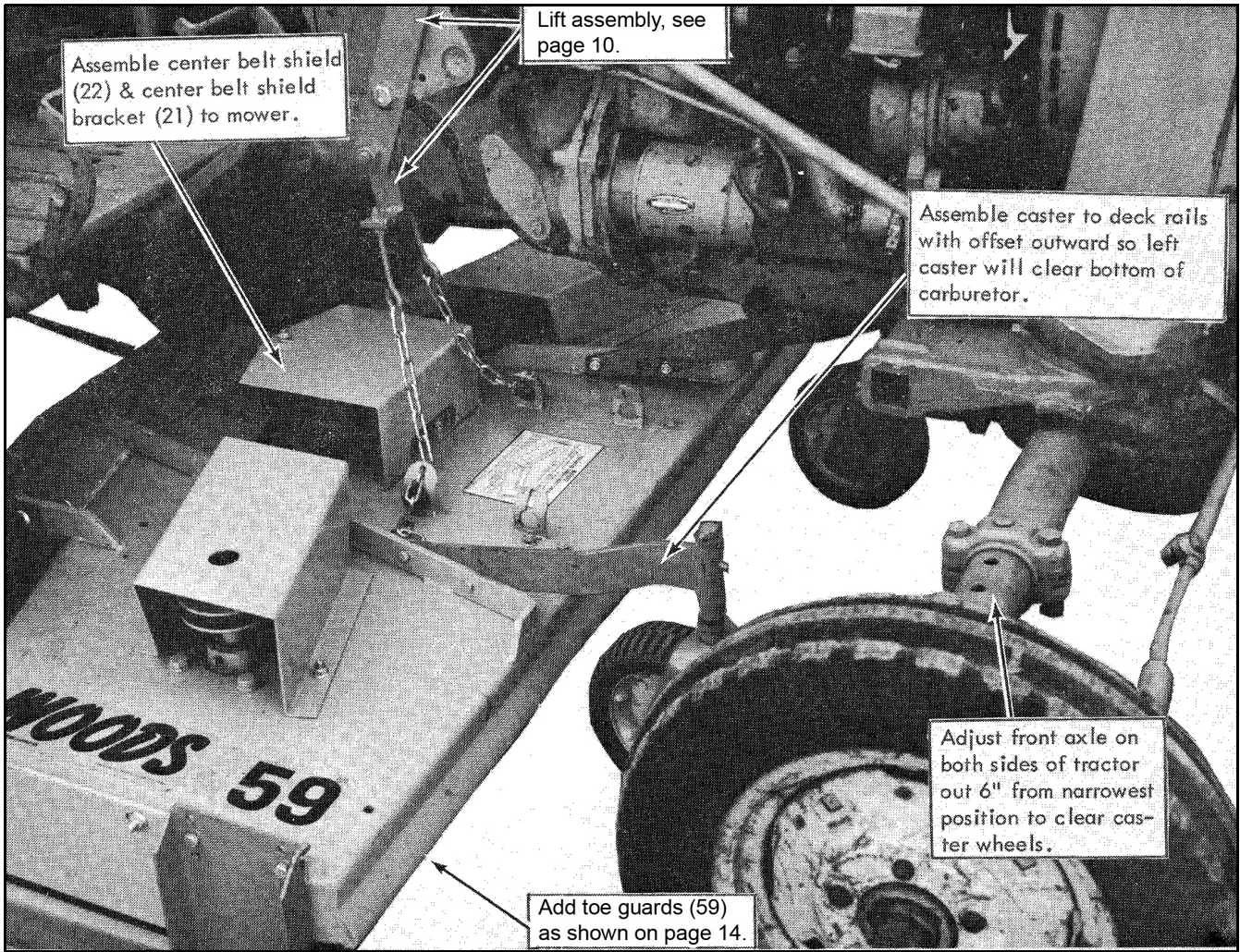

Figure 10. 59CL-4 Lift Assembly & Caster Assembly Photo

# DEALER CHECK LISTS

## **PRE-DELIVERY CHECK LIST**

(DEALER'S RESPONSIBILITY)

Inspect the equipment thoroughly after assembly to ensure it is set up properly before delivering it to the customer. The following check lists are a reminder of points to inspect. Check off each item as it is found satisfactory or after proper adjustment is made.

- \_\_\_ Check that all safety decals are installed and in good condition. Replace if damaged.
- \_\_\_ Check that shields and guards are properly installed and in good condition. Replace if damaged.
- \_\_\_ Properly attach implement to tractor and make all necessary adjustments.
- \_\_\_ Check all bolts to be sure they are tight.
- \_\_\_ Check and grease all lubrication points as identified in "Service".
- \_\_\_ Check that blades have been properly installed.

## **DELIVERY CHECK**

(DEALER'S RESPONSIBILITY)

- \_\_\_ Instruct customer how to lubricate and explain importance of lubrication.
- \_\_\_ Point out the safety decals. Explain their meaning and the need to keep them in place and in good condition. Emphasize the increased safety hazards when instructions are not followed.
- \_\_\_ Present Operator's Manual and request that customer and all operators read it before operating equipment. Point out the manual safety rules, explain their meanings and emphasize the increased safety hazards that exist when safety rules are not followed.
- \_\_\_ Show customer the safe, proper procedures to be used when mounting, dismounting, and storing equipment.
- \_\_\_ Point out all guards and shields. Explain their importance and the safety hazards that exist when not kept in place and in good condition.

# 59CL-4 & 59CLF-4 MAIN ASSEMBLY

- 53 - COMPLETE DECAL SET
- 61 - FRENCH SAFETY DECAL SET

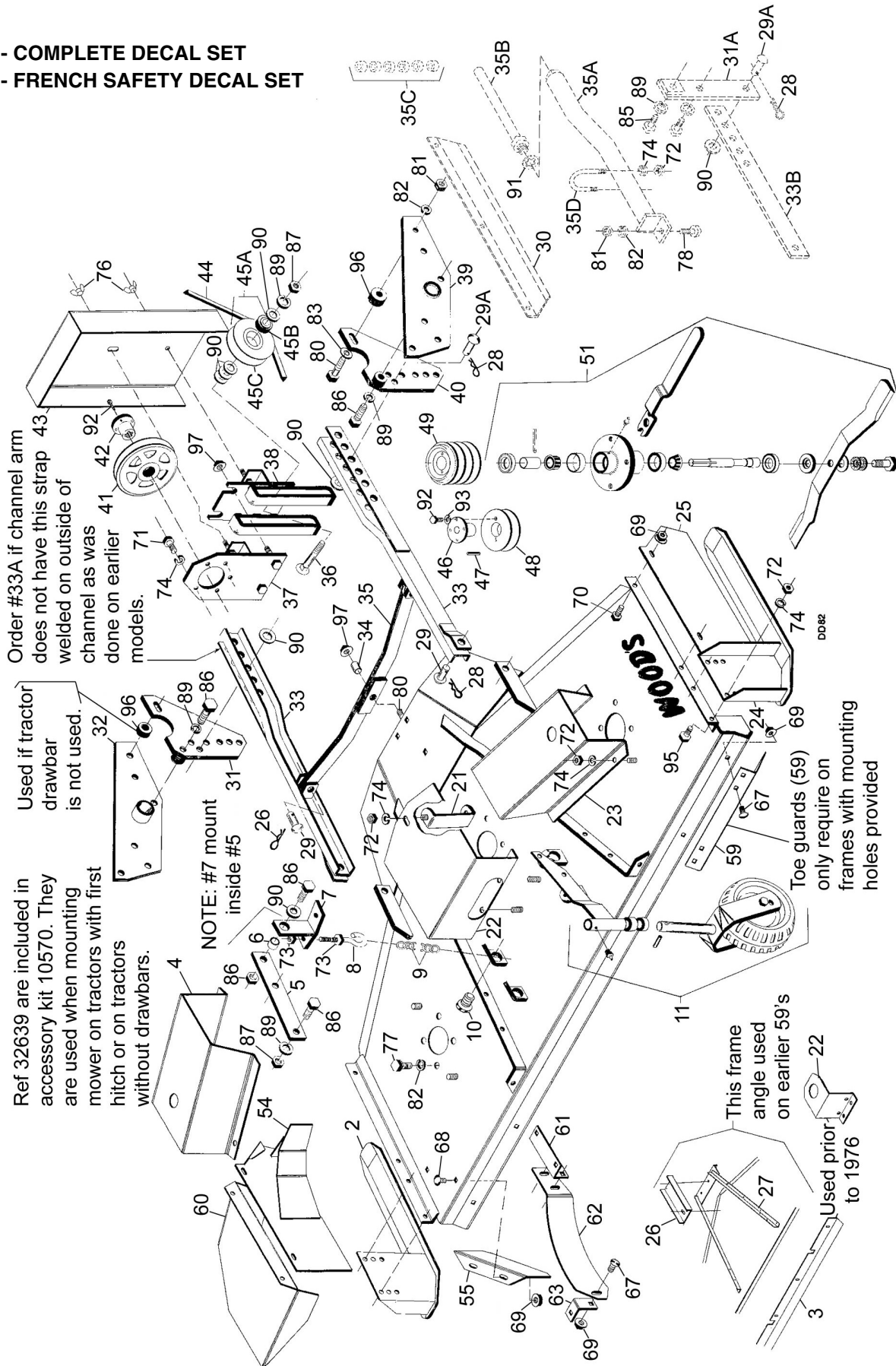

**16 Parts**



## 59CL-4 & 59CLF-4 MAIN ASSEMBLY

NOTE: Mower frames sold after 1976 the front side of mower is formed down. Before they had a bolt-on front shield.

### Key For Number Used Columns

**A** Serial Number 100 through 306 (59CL-1)

**C** Serial Number 479 through 822 (59CL-3 & 59CLF-3)

**B** Serial Number 307 through 478 (59CL-2)

**D** Serial Number 823 and up (59CL-4 & 59CLF-4)

REF	PART	A	B	C	D	DESCRIPTION	REF	PART	A	B	C	D	DESCRIPTION
1	9700	1	1	1	1	Frame shipping unit	41	3493	-	-	1	1	PTO Sheave, 1BK 6.1H
2	4141	1	1	1	1	Right side skid	41A	1505	1	1	-	-	PTO Sheave, 1BK 7.4H
3	5818	1	1	1	1	Front shield (prior to 1975)	42	1506	1	1	1	1	10-Spline bushing with bolts
4	25506	1	1	1	1	Right belt shield	43	3501	-	-	1	1	Rear V-belt shield
5	4176	1	1	1	1	Upper attachment arm	44	3492	-	-	1	1	W172 V-Belt, special <b>-or-</b>
6	484	1	1	1	1	5/8 x 1 x 7/16 HT Sleeve	44	4152	1	1	-	-	W180 V-Belt, special
7	4174	1	1	1	1	Chain attachment bracket	45A	4336	2	2	2	2	V-Groove idler w/ bearing, rt
8	4153	2	2	2	2	3/8 NC x 5 Open eyebolt	45B	6095	2	2	2	2	.626 ID x 1.85 OD Ball bearing
9	4215	-	2	2	2	2/0 Straight link chain 10-link	45C	4335	2	2	2	2	4.50 OD V-Groove idler sheave less bearing, right
10	18336	-	-	-	2	Caplug, 1-1/16 - 121D SAE thread <b>-or-</b>	46	4227	3	3	3	3	H3/4 Strt bushing w/ bolts
10	4155	2	2	2	2	1/4 Cold shut repair link (not shown)(on earlier models)	47	3885 *	3	3	3	3	3/16 x 3/16 x 1-1/4 Key
11	-----	**	**	**	1	Pair of casters (see page 20)	48	4226	2	2	2	2	1 BK 3.9H Sheave
21	25557	-	-	-	1	Center belt shield bracket	49	6126	1	1	1	1	3 BK 3.9PD H Sheave
22	25555	-	-	-	1	Center belt shield <b>-or-</b>	51	-----	3	3	3	3	Spindle & blades (see page 19)
22	4130	1	1	1	1	Center shield (for mowers prior to mid 1975)	53	5753 †	-	-	-	1	Complete decal set
23	25507	1	1	1	1	Left belt shield	54	25512 †	-	-	-	1	Right side shield with baffle
24	4142	1	1	1	1	Left side skid	55	25508 †	-	-	-	1	Front corner baffle
25	25513	1	1	1	1	Left side shield	56	25532 †	-	-	-	1	Center baffle rear mtg angle
26	-----	-	-	1	1	Channel brace	57	25509 †	-	-	-	1	Center baffle
27	-----	1	1	1	1	Frame angle	58	25531 †	-	-	-	1	Center baffle frt mtg lug
28	2688 *	4	4	6	6	1/8 Safety pin	59	26516 †	-	-	-	2	Front toe guard with safety
29	4097	4	4	4	4	5/8 x 1-1/2 Clevis pin	60	26520 †	-	-	-	1	Side discharge chute
29A	410	2	2	2	2	5/8 x 1-3/4 Clevis pin	61	52310 †	1	1	1	1	French safety decal set
30	4145	2	2	2	-	Rear shield	67	24597 *	-	-	-	6	3/8NC x 3/4 Carriage bolt
31	13870	-	-	1	1	Right vertical push arm	68	6697 *	-	-	-	2	3/8 NC x 1 Carriage bolt
31A	-----	2	2	-	-	Attachment arm	69	14350 *	-	-	-	12	3/8 NC Flange lock nut
32	3369	-	-	1	1	Rt attach place (CLF only)	70	1263 *	35	35	31	22	3/8 NC x 1" HHCS GR5
33	13314	-	-	2	2	Push channel with clevis bar	71	976 *	5	5	5	5	3/8 NC x 1-1/2 HHCS GR5
33B	4160	2	2	-	-	Adjustment arm	72	835 *	41	41	36	36	3/8 NC Hex nut
34	3504	-	-	1	1	1/2 x 5/8 x 1-1/16 Sleeve HT	73	3298 *	4	4	4	4	3/8 NC Hex nut plated
35	13313	-	-	1	1	Crosswise rear support	74	838 *	46	46	41	41	3/8 Lock washer
35A	4165	1	1	-	-	Offset pipe frame	75	565 *	9	9	11	11	3/8 Flat washer
35B	4159	1	1	-	-	Guide rod	76	1287 *	1	2	2	2	3/8 NC Wing nut
35C	1791	-	6	-	-	5/8 x 1 x 9/16 HT Sleeve (for raising fast-hitch)	77	4119	12	12	12	12	1/2 NF x 1 HHCS GR5
35D	4156	1	1	-	-	3/8 U-Bolt	78	745 *	1	1	-	-	1/2 NC x 1-1/4 HHCS GR5
36	5655 *	2	2	2	2	5/8 NC x 3-1/2 Carriage bolt	79	742 *	3	3	-	-	1/2 NC x 1-3/4 HHCS GR5 (NS)
37	3510	-	-	1	1	Upper idler bracket	80	948 *	-	-	3	3	1/2 NC x 2 HHCS GR5
38	3506	-	-	1	1	Lower idler bracket	81	1093 *	4	4	5	2	1/2 NC Hex nut
39	3368	-	-	1	1	Left attach plate (CLF only)	82	855 *	16	16	17	14	1/2 Lock washer
40	13871	-	-	1	1	Left vertical push arm	83	854 *	12	12	3	2	1/2 Flat washer
							84	6268 *	-	-	8	8	5/8 NC x 1-1/4 HHCS GR5

## 59CL-4 & 59CLF-4 MAIN ASSEMBLY CONTINUED

REF	PART	A	B	C	D	DESCRIPTION
85	738 *	4	4	-	-	5/8 NC x 1-1/2 HHCS GR5
86	614 *	3	3	3	3	5/8 NC x 1-3/4 HHCS GR5
87	230 *	8	8	4	4	5/8 NC Hex nut
88	6239 *	1	1	1	1	5/8 Lock nut
89	1286 *	8	8	12	12	5/8 Lock washer
90	692 *	13	13	13	13	5/8 Flat washer
91	3627	1	1	-	-	1" Shakeproof washer
92	2457 *	8	8	8	3	1/4 NC x 3/4 HHCS GR5
93	1985 *	-	-	6	6	1/4 Standard lock washer
94	-----	1	1	1	1	Leaf mulcher (see page 21)

REF	PART	A	B	C	D	DESCRIPTION
95	12169 *	4	4	4	4	3/8 NC x 1-1/4 HHCS, GR5
96	13258	-	-	2	2	5/8 x 1-3/8 x 5/8 Flat washer
97	11900 *	-	-	-	3	1/2 NC Flange lock nut

\* Obtain locally

\*\* The 6760 casters may be used on "A", "B", & "C" machines by drilling two 13/32 diameter holes 4" apart, through frame angle, the first hole being 3-1/2" from front end of frame angle. For repair of "A", "B" & "C" series casters, see page 20 drawing and parts list.

† For mowers sold after 1976. See note on previous page.

## SPINDLE ASSEMBLY

REF	PART	QTY	DESCRIPTION
1	4116	1	Spindle
2	5089	2	Seal
3	4114	1	Sleeve
4	4115	1	Pin
5	4107	2	Bearing cone
6	4117	1	Housing with cups
7	4106	2	Bearing cup
8	1972	1	Grease fitting
9	4105	1	Spindle shaft
10	4110	1	Shoulder washer
11	6950KT	1	20-1/4 Medium suction blade
11	26559KT	1	20-1/4 Low suction blade
12	10658	1	5/8 NC x 1-1/2 Nylok bolt
13	3490	1	Blade bolt wrench
14	2974	1	Spindle lock wrench
16	10635	2	5/8 Cup washer
17	692	1	5/8 Flat washer
18	1015825	1	Blade bolt and washers, complete

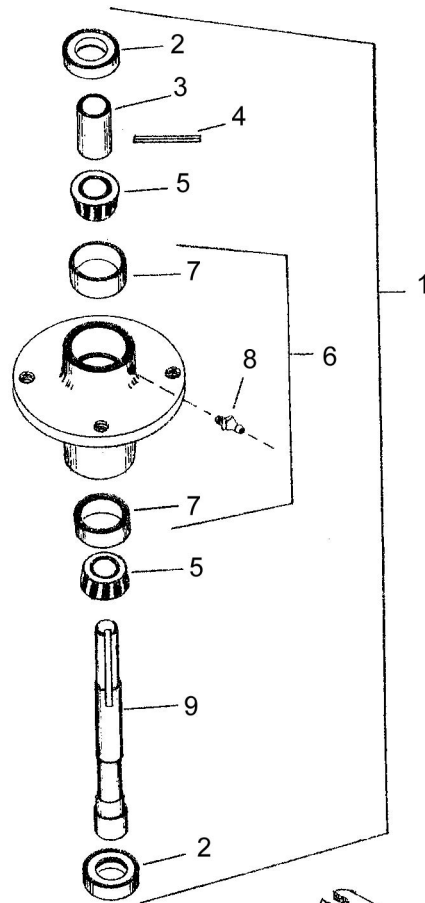

**NOTE:** When difficulty is experienced with a mower spindle, time and trouble will be saved by buying a complete new assembly.

**NOTE:** Repair shaft (9) and repair sleeve (3) do not have a hole drilled in them for pin (4). After new parts have been assembled and proper bearing adjustment obtained, drill a 3/16 diameter hole through sleeve and shaft. Drive in Sel-lock pin to hold proper bearing adjustment.

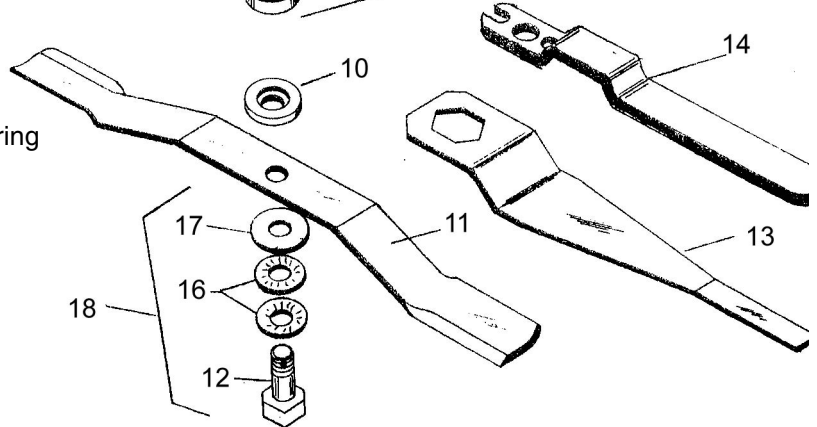

## 59 & L59 CASTERS

REF	PART	QTY	DESCRIPTION
1	29750	1	59 & L59 Right & left caster bundle
2	12243	1	Caster yoke (includes bolt, nut & 2 sleeves)
3	29746 (a)	1	Right caster arm asy, 13-5/32 long <b>-or-</b>
3	6761 (a)	1	Right caster arm, 16-5/32 long
4	29747 (a)	1	Left caster arm, 13-5/32 long <b>-or-</b>
4	18424 (a)	1	Left caster arm, 16-5/32 long
5	19703	1	8" HD Caster wheel with sleeve
7	2909 *	1	Straight 1/4 self-tapping grease fitting (for steel wheel) <b>-or-</b>
7	195 *	1	Straight 1/8P thread grease fitting (for polyethylene wheel)
8	21020	1	1/4 x 1-1/4 Spirol pin <b>-or-</b>
8	1285 *	1	1/4 x 1-1/2 Cotter pin
9	12296 *	1	1/4 - 28 Straight grease fitting 15/32" long
10	12169 *	2	3/8 NC x 1-1/4 HHCS GR5
11	838 *	2	3/8 Standard lock washer
12	835 *	2	3/8 NC Hex nut, plated
13	765 *	1	1/2 NC Hex lock nut
14	23479	1	1/2 NC x 5 HHCS GR5
15	29368 (c)	1	1/2 x 3/4 OD x 3-3/8 Sleeve <b>-or-</b>
15	12242 (c)	1	17 GA Wall x 5/8 OD x 3-3/8 tube
16	29375 (b)	2	3/4 Bore flanged bearing for 1-1/8 hole <b>-or-</b>
16	4228 (b)	2	5/8 Bore flanged bearing for 1-3/8 hole <b>-or-</b>
16	2905 (b)	2	5/8 Bore flanged bearing for 1-1/8 hole <b>-or-</b>
16	65578 (b)	2	3/4 Bore x 1.385 flanged wheel bearing with groove
17	22240	2	3/4 x 1-3/16 x 10 GA Washer
18	4181	2	25/32 x 1 x 1/2 Heat-treated sleeve

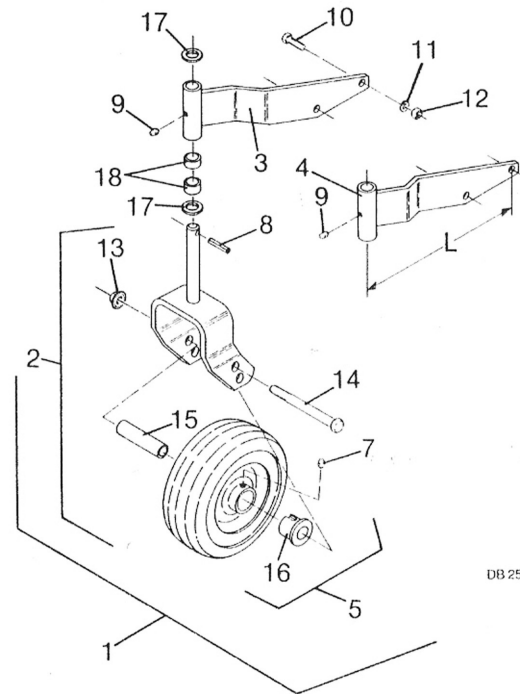

DB 2527

\* Obtain locally

(a) For proper caster arm identification, refer to dimension "L" as shown on drawing. The caster arms may be used on either side to obtain best fit.

(b) Measure old bearing.

(c) Measure outside diameter of old sleeve.

# LEAF MULCHER

REF	PART	QTY	DESCRIPTION
A	7080	1	Model 59 Leaf mulcher -or-
A	13482	1	Model L306 Leaf mulcher
1	----	1	Leaf mulcher weldment
2	7076	1	Angle lug
5	23218	1	3/8 Schd 40 pipe 5/8 long
7	839 *		3/8 NC x 1 HHCS GR5
8	979 *		3/8 NC x 1-1/2 HHCS GR5
9	565 *		3/8 Flat washer
10	838 *		3/8 Lock washer
11	835 *		3/8 NC Hex nut

\* Standard hardware, obtain locally

This mower frame has a bolt on front shield

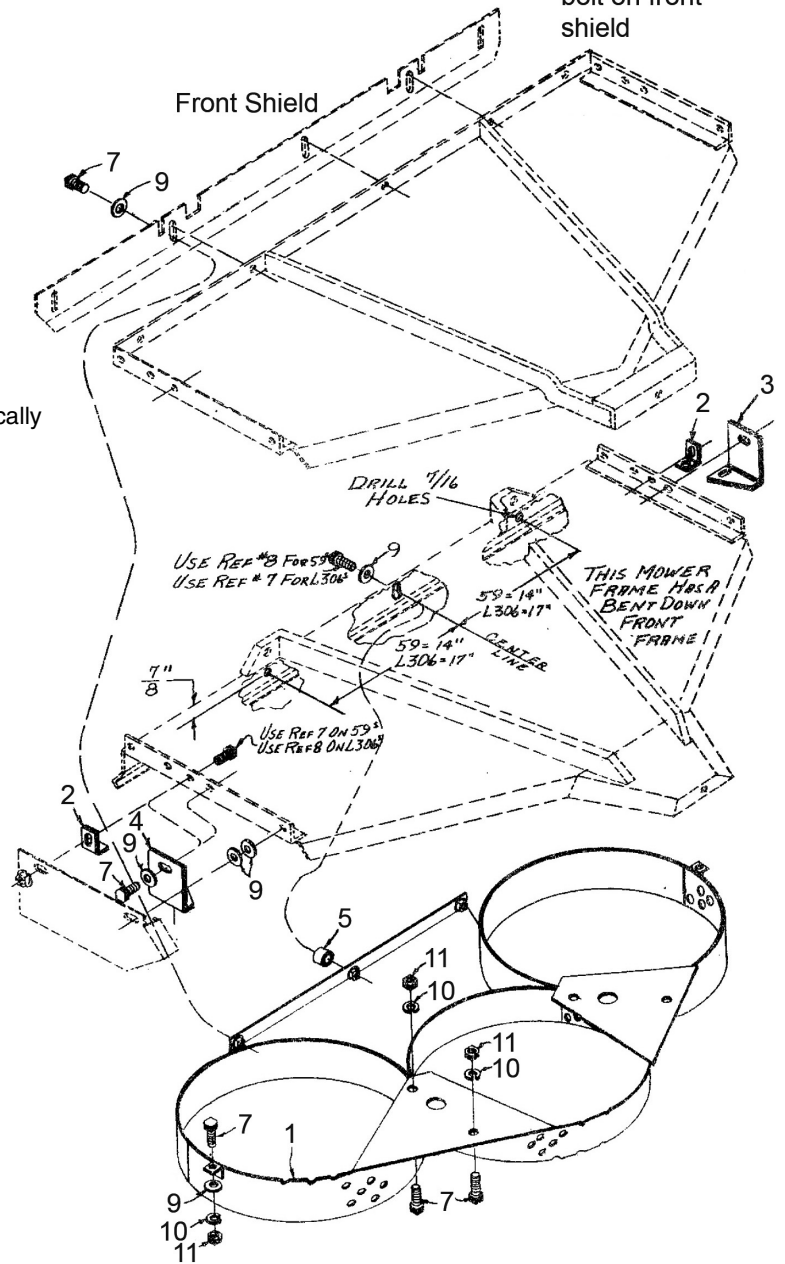

# BOLT TORQUE CHART

Always tighten hardware to these values unless a different torque value or tightening procedure is listed for a specific application.

Fasteners must always be replaced with the same grade as specified in the manual parts list.

Always use the proper tool for tightening hardware: SAE for SAE hardware and Metric for metric hardware.

Make sure fastener threads are clean and you start thread engagement properly.

All torque values are given to specifications used on hardware defined by SAE J1701 MAR 99 & J1701M JUL 96.

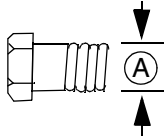

## SAE SERIES TORQUE CHART

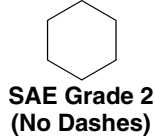

SAE Bolt Head Identification



Ⓐ Diameter (Inches)	Wrench Size	MARKING ON HEAD					
		SAE 2		SAE 5		SAE 8	
		lbs-ft	N-m	lbs-ft	N-m	lbs-ft	N-m
1/4"	7/16"	6	8	10	13	14	18
5/16"	1/2"	12	17	19	26	27	37
3/8"	9/16"	23	31	35	47	49	67
7/16"	5/8"	36	48	55	75	78	106
1/2"	3/4"	55	75	85	115	120	163
9/16"	13/16"	78	106	121	164	171	232
5/8"	15/16"	110	149	170	230	240	325
3/4"	1-1/8"	192	261	297	403	420	569
7/8"	1-5/16"	306	416	474	642	669	907
1"	1-1/2"	467	634	722	979	1020	1383

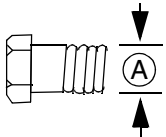

## METRIC SERIES TORQUE CHART

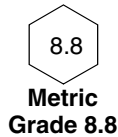

Metric Bolt Head Identification

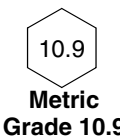

Ⓐ Diameter & Thread Pitch (Millimeters)	Wrench Size	Coarse Thread				Fine Thread				Ⓐ Diameter & Thread Pitch (Millimeters)
		Marking on Head				Marking on Head				
		Metric 8.8		Metric 10.9		Metric 8.8		Metric 10.9		
		N-m	lbs-ft	N-m	lbs-ft	N-m	lbs-ft	N-m	lbs-ft	
6 x 1.0	10 mm	8	6	11	8	8	6	11	8	6 x 1.0
8 x 1.25	13 mm	20	15	27	20	21	16	29	22	8 x 1.0
10 x 1.5	16 mm	39	29	54	40	41	30	57	42	10 x 1.25
12 x 1.75	18 mm	68	50	94	70	75	55	103	76	12 x 1.25
14 x 2.0	21 mm	109	80	151	111	118	87	163	120	14 x 1.5
16 x 2.0	24 mm	169	125	234	173	181	133	250	184	16 x 1.5
18 x 2.5	27 mm	234	172	323	239	263	194	363	268	18 x 1.5
20 x 2.5	30 mm	330	244	457	337	367	270	507	374	20 x 1.5
22 x 2.5	34 mm	451	332	623	460	495	365	684	505	22 x 1.5
24 x 3.0	36 mm	571	421	790	583	623	459	861	635	24 x 2.0
30 x 3.0	46 mm	1175	867	1626	1199	1258	928	1740	1283	30 x 2.0

### Typical Washer Installations

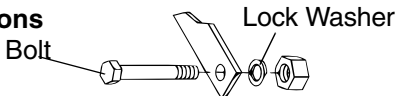

### Flat Washer

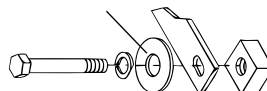

8/9/00

# BOLT SIZE CHART

**NOTE:** Chart shows bolt thread sizes and corresponding head (wrench) sizes for standard SAE and metric bolts.

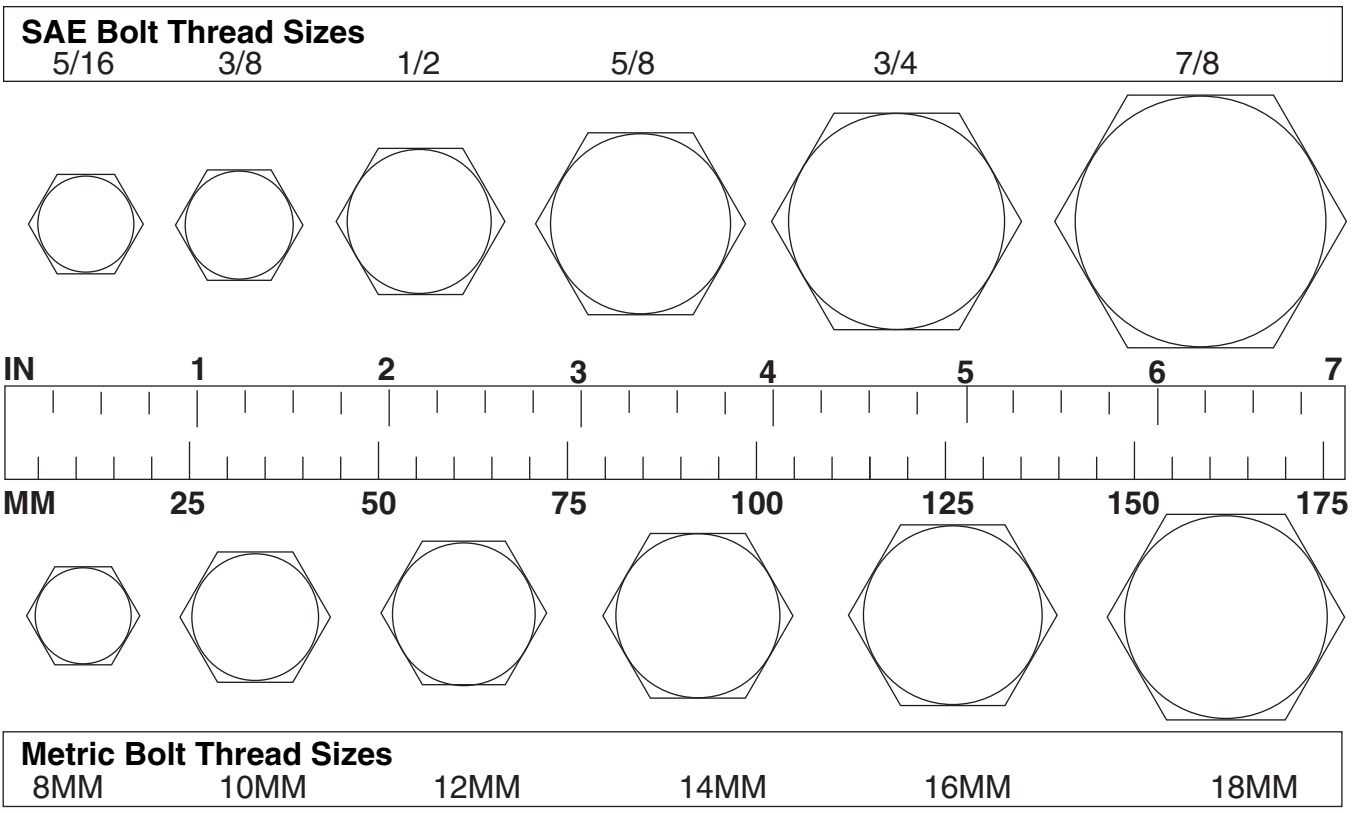

## ABBREVIATIONS

AG .....	Agriculture	MPa.....	Mega Pascal
ASABE.....	American Society of Agricultural & Biological Engineers (formerly ASAE)	N.....	Newton
ASAE .....	American Society of Agricultural Engineers	NC .....	National Coarse
ATF .....	Automatic Transmission Fluid	NF .....	National Fine
BSPP .....	British Standard Pipe Parallel	NPSM.....	National Pipe Straight Mechanical
BSPTM .....	British Standard Pipe Tapered Male	NPT .....	National Pipe Tapered
CV.....	Constant Velocity	NPT SWF .....	National Pipe Tapered Swivel Female
CCW .....	Counter-Clockwise	ORBM .....	O-Ring Boss - Male
CW.....	Clockwise	P.....	Pitch
F .....	Female	PBY .....	Power-Beyond
FT .....	Full Thread	psi.....	Pounds per Square Inch
GA .....	Gauge	PTO .....	Power Take Off
GR (5, etc.) .....	Grade (5, etc.)	QD.....	Quick Disconnect
HHCS .....	Hex Head Cap Screw	RH.....	Right Hand
HT.....	Heat-Treated	ROPS .....	Roll-Over Protective Structure
JIC .....	Joint Industry Council 37° Degree Flare	RPM .....	Revolutions Per Minute
LH.....	Left Hand	RT .....	Right
LT.....	Left	SAE .....	Society of Automotive Engineers
m.....	Meter	UNC .....	Unified Coarse
mm.....	Millimeter	UNF .....	Unified Fine
M.....	Male	UNS.....	Unified Special

# WARRANTY

(All Models Except Mow'n Machine™ Zero-Turn Mowers and Woods Boundary™ Utility Vehicles)

Please Enter Information Below and Save for Future Reference.

Date Purchased: \_\_\_\_\_ From (Dealer): \_\_\_\_\_  
 Model Number: \_\_\_\_\_ Serial Number: \_\_\_\_\_

Woods Equipment Company ("WOODS") warrants this product to be free from defect in material and workmanship. Except as otherwise set forth below, the duration of this Warranty shall be for TWELVE (12) MONTHS COMMENCING ON THE DATE OF DELIVERY OF THE PRODUCT TO THE ORIGINAL PURCHASER.

Woods backhoe models BH70-X, BH80-X, and BH90-X are warranted for two (2) years from the date of delivery to the original purchaser.

The warranty periods for specific parts or conditions are listed below:

Part or Condition Warranted	Model Number	Duration (from date of delivery to the original purchaser)
Gearbox components	BW1260, BW1800	8 years
	BB48X, BB60X, BB72X, BB84X, BB600X, BB720X, BB840X, BB6000X, BB7200X, BB8400X, DS1260, DSO1260, DS1440, TS1680, BW126-2, BW180-2	6 years
	PHD25, PHD35, PHD65, PHD95, 2162, 3240, DS96, DS120, RCC42, RM550-2, RM660-2, RM990-3, PRD6000, PRD7200, PRD8400, 7144RD-2, 9180RD-2, 9204RD-2, S15CD, S20CD, S22CD, S25CD, S27CD	5 years
	RDC54, RD60, RD72	3 years (1 year if used in rental or commercial applications)
Blade spindles	RM550-2, RM660-2, RM990-3, PRD6000, PRD7200, PRD8400, 7144RD-2, 9180RD-2, 9204RD-2	3 years
Rust-through	BB600, BB720, BB840, BB6000, BB7200, BB8400, BW126-2, BW180-2, BW1260, BW1800, 2162, 3240, DS1260, DSO1260, DS1440, TS1680	10 years

Under no circumstances will this Warranty apply in the event that the product, in the good faith opinion of WOODS, has been subjected to improper operation, improper maintenance, misuse, or an accident. This Warranty does not apply in the event that the product has been materially modified or repaired by someone other than WOODS, a WOODS authorized dealer or distributor, and/or a WOODS authorized service center. This Warranty does not cover normal wear or tear, or normal maintenance items. This Warranty also does not cover repairs made with parts other than those obtainable through WOODS.

This Warranty is extended solely to the original purchaser of the product. Should the original purchaser sell or otherwise transfer this product to a third party, this Warranty does not transfer to the third party purchaser in any way. There are no third party beneficiaries of this Warranty.

WOODS makes no warranty, express or implied, with respect to engines, batteries, tires or other parts or accessories not manufactured by WOODS. Warranties for these items, if any, are provided separately by their respective manufacturers.

WOODS' obligation under this Warranty is limited to, at WOODS' option, the repair or replacement, free of charge, of the product if WOODS, in its sole discretion, deems it to be defective or in noncompliance with this Warranty. **The product must be returned to WOODS with proof of purchase within thirty (30) days after such defect or noncompliance is discovered or should have been discovered, routed through the dealer and distributor from whom the purchase was made, transportation charges prepaid.** WOODS shall complete such repair or replacement within a reasonable time after WOODS receives the product. **THERE ARE NO OTHER REMEDIES UNDER THIS WARRANTY. THE REMEDY OF REPAIR OR REPLACEMENT IS THE SOLE AND EXCLUSIVE REMEDY UNDER THIS WARRANTY.**

THERE ARE NO WARRANTIES WHICH EXTEND BEYOND THE DESCRIPTION ON THE FACE OF THIS WARRANTY. WOODS MAKES NO OTHER WARRANTY, EXPRESS OR IMPLIED, AND WOODS SPECIFICALLY DISCLAIMS ANY IMPLIED WARRANTY OF MERCHANTABILITY AND/OR ANY IMPLIED WARRANTY OF FITNESS FOR A PARTICULAR PURPOSE.

**WOODS shall not be liable for any incidental or consequential losses, damages or expenses, arising directly or indirectly from the product, whether such claim is based upon breach of contract, breach of warranty, negligence, strict liability in tort or any other legal theory.** Without limiting the generality of the foregoing, Woods specifically disclaims any damages relating to (i) lost profits, business, revenues or goodwill; (ii) loss of crops; (iii) loss because of delay in harvesting; (iv) any expense or loss incurred for labor, supplies, substitute machinery or rental; or (v) any other type of damage to property or economic loss.

This Warranty is subject to any existing conditions of supply which may directly affect WOODS' ability to obtain materials or manufacture replacement parts.

No agent, representative, dealer, distributor, serviceperson, salesperson, or employee of any company, including without limitation, WOODS, its authorized dealers, distributors, and service centers, is authorized to alter, modify, or enlarge this Warranty.

Answers to any questions regarding warranty service and locations may be obtained by contacting:

**Woods Equipment Company**  
 2606 South Illinois Route 2  
 Post Office Box 1000  
 Oregon IL 61061  
 800-319-6637 tel  
 800-399-6637 fax  
 www.WoodsEquipment.com



**ALITEC™**  
**BMP®**  
**CENTRAL FABRICATORS®**  
**GANNON®**  
**GILL®**  
**WAIN-ROY®**  
**WOODS®**





## WARRANTY

(Replacement Parts For All Models Except Mow'n Machine™  
Zero-Turn Mowers and Woods Boundary™ Utility Vehicles)

Woods Equipment Company ("WOODS") warrants this product to be free from defect in material and workmanship for a period of ninety (90) days from the date of delivery of the product to the original purchaser with the exception of V-belts, which will be free of defect in material and workmanship for a period of 12 months.

Under no circumstances will this Warranty apply in the event that the product, in the good faith opinion of WOODS, has been subjected to improper operation, improper maintenance, misuse, or an accident. This Warranty does not cover normal wear or tear, or normal maintenance items.

This Warranty is extended solely to the original purchaser of the product. Should the original purchaser sell or otherwise transfer this product to a third party, this Warranty does not transfer to the third party purchaser in any way. There are no third party beneficiaries of this Warranty.

WOODS' obligation under this Warranty is limited to, at WOODS' option, the repair or replacement, free of charge, of the product if WOODS, in its sole discretion, deems it to be defective or in noncompliance with this Warranty. **The product must be returned to WOODS with proof of purchase within thirty (30) days after such defect or noncompliance is discovered or should have been discovered, routed through the dealer and distributor from whom the purchase was made, transportation charges prepaid.** WOODS shall complete such repair or replacement within a reasonable time after WOODS receives the product. **THERE ARE NO OTHER REMEDIES UNDER THIS WARRANTY. THE REMEDY OF REPAIR OR REPLACEMENT IS THE SOLE AND EXCLUSIVE REMEDY UNDER THIS WARRANTY.**

THERE ARE NO WARRANTIES WHICH EXTEND BEYOND THE DESCRIPTION ON THE FACE OF THIS WARRANTY. WOODS MAKES NO OTHER WARRANTY, EXPRESS OR IMPLIED, AND WOODS SPECIFICALLY DISCLAIMS ANY IMPLIED WARRANTY OF MERCHANTABILITY AND/OR ANY IMPLIED WARRANTY OF FITNESS FOR A PARTICULAR PURPOSE.

**WOODS shall not be liable for any incidental or consequential losses, damages or expenses, arising directly or indirectly from the product, whether such claim is based upon breach of contract, breach of warranty, negligence, strict liability in tort or any other legal theory.** Without limiting the generality of the foregoing, Woods specifically disclaims any damages relating to (i) lost profits, business, revenues or goodwill; (ii) loss of crops; (iii) loss because of delay in harvesting; (iv) any expense or loss incurred for labor, supplies, substitute machinery or rental; or (v) any other type of damage to property or economic loss.

This Warranty is subject to any existing conditions of supply which may directly affect WOODS' ability to obtain materials or manufacture replacement parts.

No agent, representative, dealer, distributor, service person, salesperson, or employee of any company, including without limitation, WOODS, its authorized dealers, distributors, and service centers, is authorized to alter, modify, or enlarge this Warranty.

Answers to any questions regarding warranty service and locations may be obtained by contacting:

### Woods Equipment Company

2606 South Illinois Route 2  
Post Office Box 1000  
Oregon IL 61061

800-319-6637 tel  
800-399-6637 fax  
[www.WoodsEquipment.com](http://www.WoodsEquipment.com)

# WOODS®

**ALITEC™**  
**BMP®**  
**CENTRAL FABRICATORS®**  
**GANNON®**  
**GILL®**  
**WAIN-ROY®**  
**WOODS®**

**Woods Equipment  
Company**

2606 South Illinois Route 2  
Post Office Box 1000  
Oregon, Illinois 61061 USA

800-319-6637 tel  
800-399-6637 fax  
[www.WoodsEquipment.com](http://www.WoodsEquipment.com)



©2007 Woods Equipment Company. All rights reserved. WOODS, the Woods logo, and "Tested. Proven. Unbeatable." are trademarks of Woods Equipment Company. All other trademarks, trade names, or service marks not owned by Woods Equipment Company that appear in this manual are the property of their respective companies or mark holders. Specifications subject to change without notice.